

Monitoring Strategies & Solutions for Flue Gas Pollutants (CEMS)

Roland Zepeck

2017_09_26-28

CEM India



JCT

Analysentechnik
GmbH

www.jct.at
sales@jct.at





JCT

Analysentechnik
GmbH

Analysing for a better world

Agenda

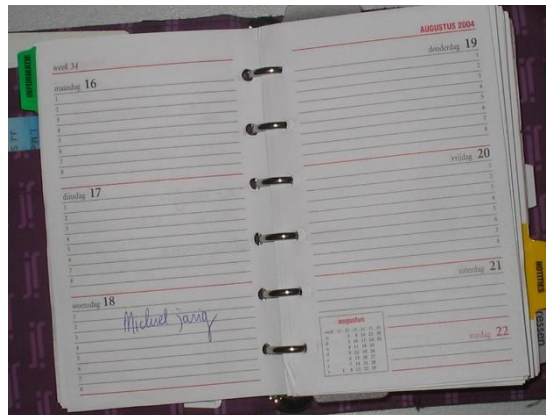

- Where do we measure?
- What do we measure?
- Regulations
- Analysers / Detection Technologies
 - In-situ
 - Conventional extractive
 - Dilution extractive
- Quality Assurance
- PEMS ?
- Conclusions



JCT

Analysentechnik
GmbH

www.jct.at
sales@jct.at



What needs to be measured where in a Thermal Power Plant?



Process Control

Emission Monitoring

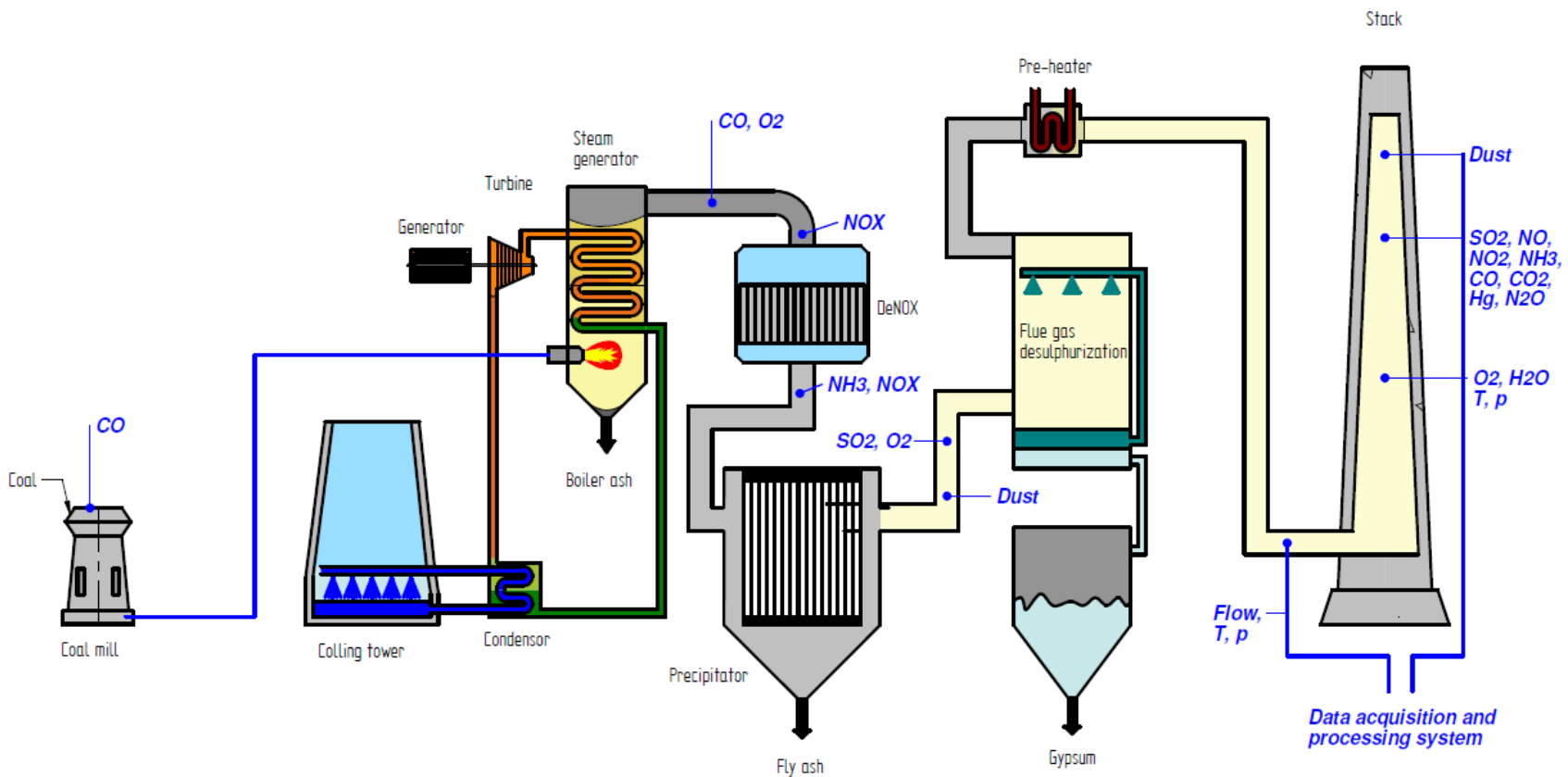

JCT

Analysentechnik
GmbH

www.jct.at
sales@jct.at



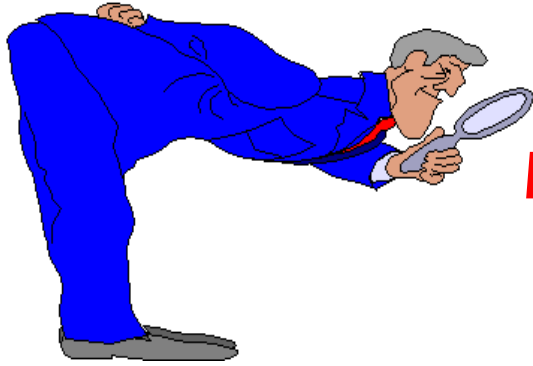

WHY MONITORING AT ALL??

If we don't know "what and how much", we don't know "how to reduce it"

Emission Monitoring documents the efficiency of Emission Control Activities



JCT

Analysentechnik
GmbH

www.jct.at
sales@jct.at



REGULATIONS



JCT
Analysetechnik
GmbH

www.jct.at
sales@jct.at



There are basically two ways of the regulatory approach:

- **U.S.A.**
 - US-EPA regulations are laid down in 40CFR60 and ASTM's
 - Instruments cannot get type-approval – there is no scheme like that in USA
 - Extensive site testing after installation is required
- **EUROPE**
 - European regulations are laid down in EN's as well as country-specific laws and regulations, f.e. in Germany: TA-Luft, BImSchG, and BImSchV 1 – 45
 - Instruments have to successfully complete type-approval (“TUEV-Test, MCERTS”) = QAL 1
 - Extensive site testing after installation is required = QAL 2

What is it we are interested in?

There are plenty of pollutants we can / have to measure:

- **Particulates:**
 - **Total Dust or Opacity, Heavy Metals**
- **Inorganic Compounds:**
- **CO, CO₂, SO₂, NO/NO₂/NO_x, NH₃, HCl, HF, Total Hg**
- **Organic Compounds:**
- **THC, Dioxins & Furans**

- **Reference Values:**
 - **O₂, H₂O, Temperature, Pressure, Gas Velocity / Flow**



JCT

Analysentechnik
GmbH

www.jct.at
sales@jct.at



CEMS DESIGN

- **CEMS (Continuous Emission Monitoring System) can be designed in three principle ways (or a combination between them):**

Direct In-Situ Analyzers

- Dust/Opacity, O₂, H₂O, CO, CO₂, SO₂, NO, NO₂, NH₃, HCl, HF
- Hg (elemental only)

Conventional Extractive Analyzers

- Dust, CO, CO₂, SO₂, NO, NO₂, NO_x, NH₃, HCl, HF, Total Hg, THC, Dioxins & Furans (Samplers only), O₂, H₂O

Dilution-based Extractive Analyzers

- Dust, SO₂, NO, NO₂, NO_x, Total Hg



JCT

Analysentechnik
GmbH

www.jct.at
sales@jct.at



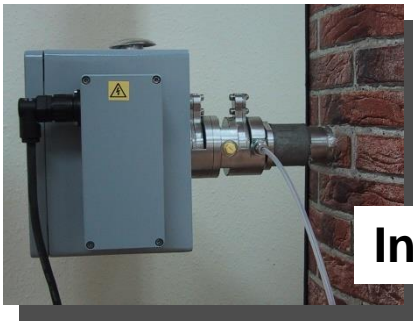
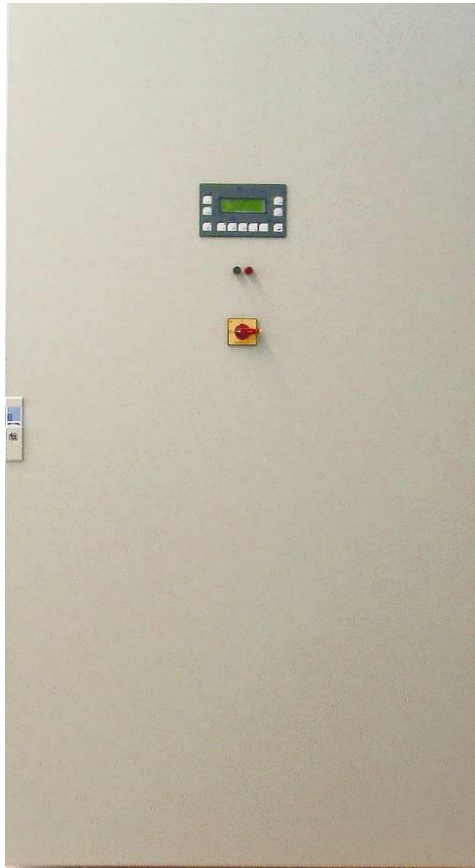

In-situ



← Extractive →



JCT
 Analysentechnik
 GmbH

www.jct.at
sales@jct.at



Dilution

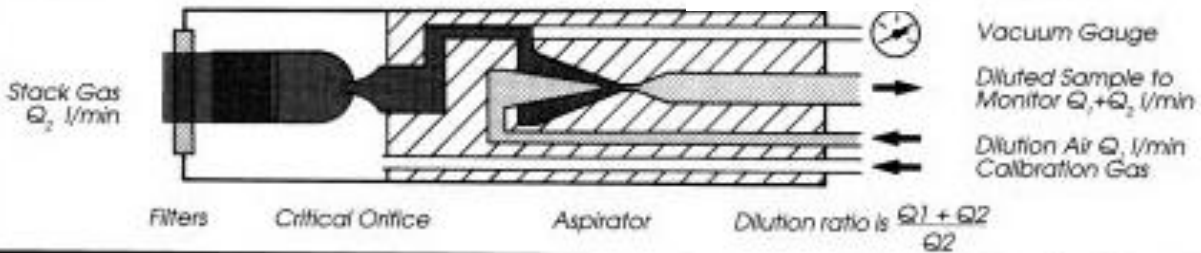

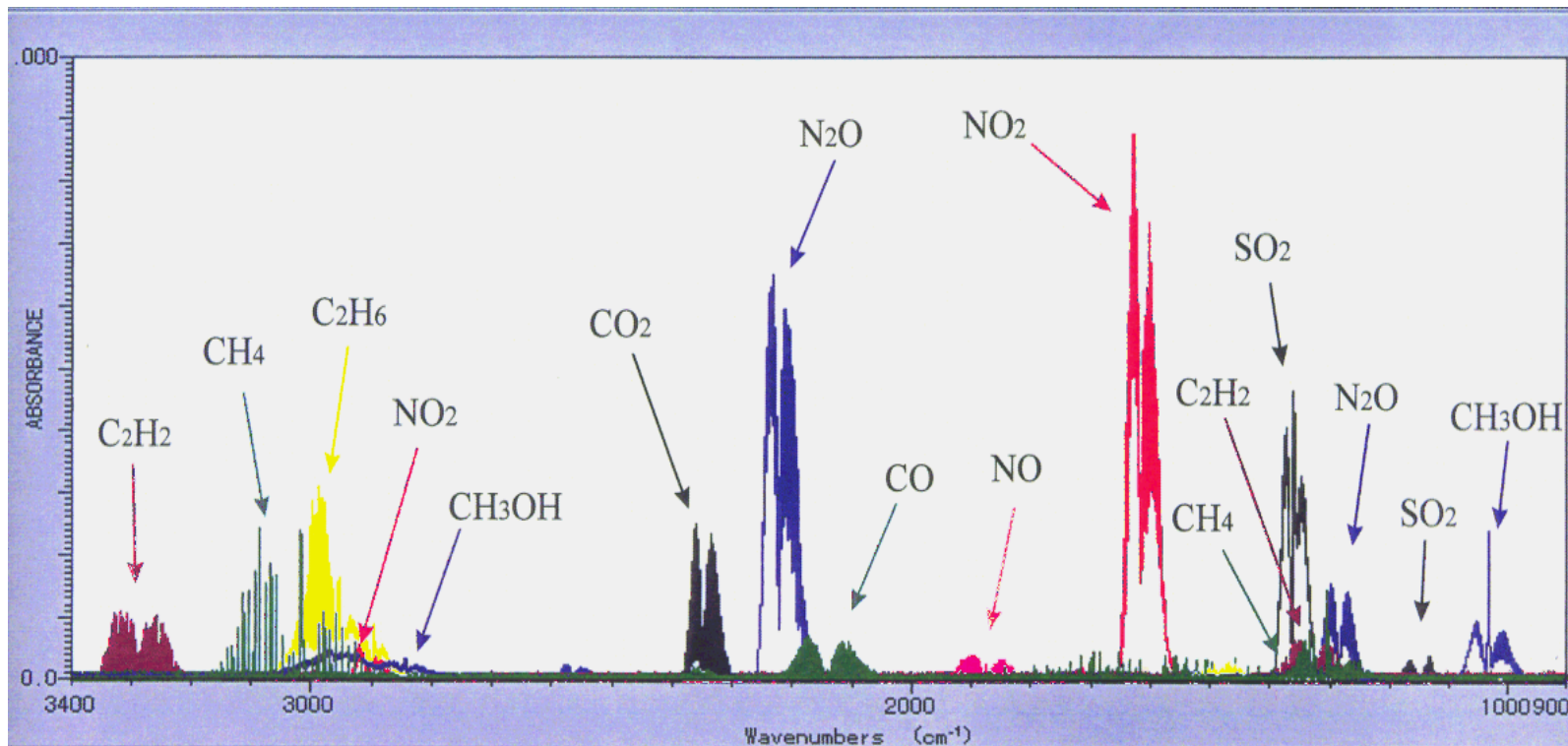

Many gaseous pollutants show absorption band(s) in the infrared wavelength band



JCT

Analystechnik
GmbH

www.jct.at
sales@jct.at



OTHER DETECTION TECHNOLOGIES ***for gas measurement***

- **UV-Absorption is used for a number of pollutants like NO and NO₂**
- **Chemiluminescence is used for NO, NO₂, NO_x**
- **FTIR Spectrometry is used as Multicomponent Analyzer**
- **Flame Ionization Detector (FID) is used for Total Hydrocarbons (THC)**
- **UV-Photometrie or CVAFS, together with sample preparation, are used for Total Mercury**
- **ZrO₂ probes are used for O₂**



JCT

Analysentechnik
GmbH

www.jct.at
sales@jct.at



DETECTION TECHNOLOGIES ***for dust measurement***

- **Light Transmission** for %-Opacity and Extinction (= calibrated into dust concentration [mg/m^3])
- Generally only accepted principle: Autocollimation (= double path light beam from one light emitter); single path light beam not for statutory measurements
- **Light Scattering** for dust concentration [mg/m^3] and low concentration ($0.5 - 250 \text{ mg}/\text{m}^3$); either backward or forward scattering
- **Extractive Beta-Gauge** instruments mainly for applications, where optical principles cannot be used (= stack gas below dewpoint; varying particle colors and/or particle size and density)
- **Triboelectric** mainly as broken bag filter detector – qualitative measurement; or **Electro-Dynamic** calibrated for dust concentration



JCT

Analysentechnik
GmbH

www.jct.at
sales@jct.at



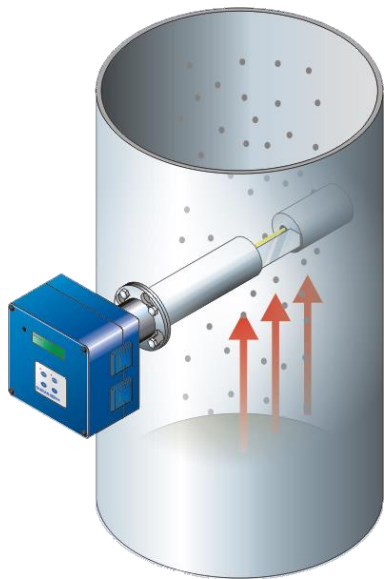
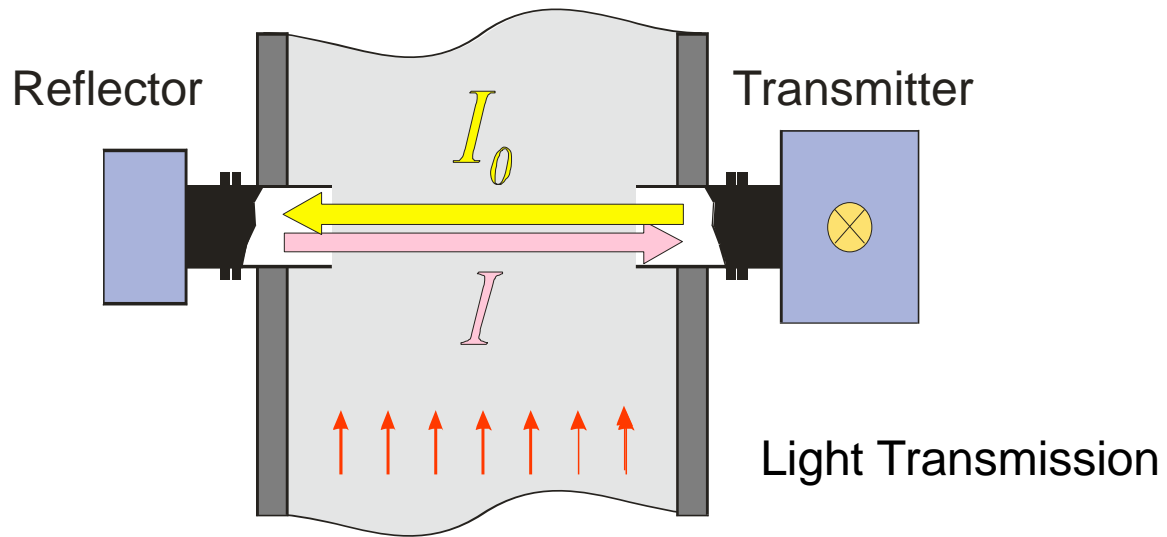

Light Scattering

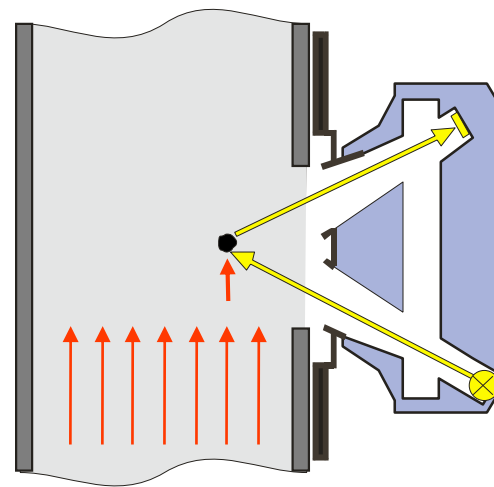

JCT
 Analysentechnik
 GmbH

www.jct.at
sales@jct.at



Extractive Beta-Gauge

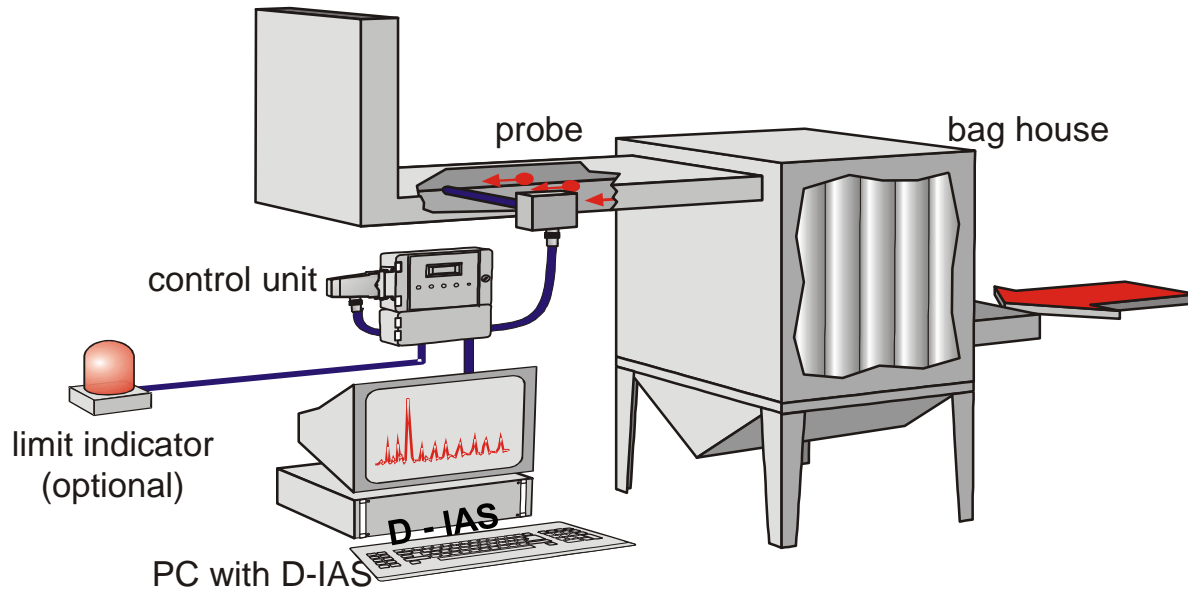

Triboelectric

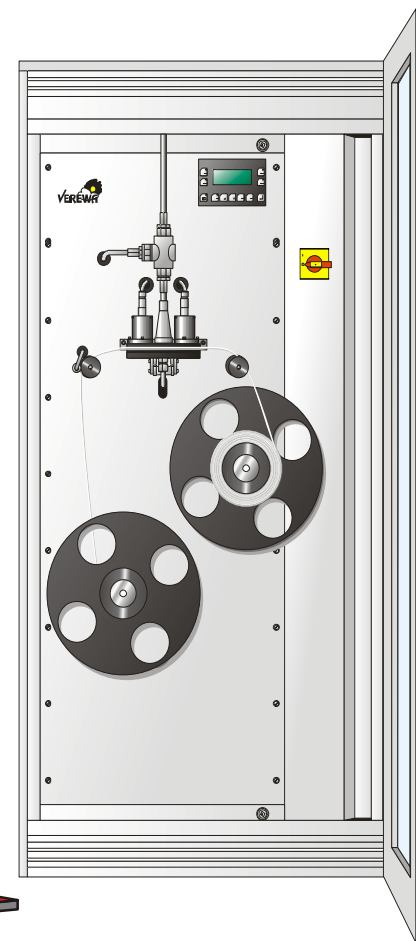

JCT

Analysentechnik
GmbH

www.jct.at
sales@jct.at



ADVANTAGE / DIS-ADVANTAGE **IN-SITU**

- No sample transport – gases / dust are analyzed in their stack environment
- Typically Multicomponent Analyzers – reduction on space and accessories
- **Unknown / Unexpected interferences possible – difficult to consider during calibration**
- **If a key component fails, the whole Multicomponent Analyzer is down**
- **Sensitivity might be depending on available pathlength (stack diameter)**



JCT

Analysentechnik
GmbH

www.jct.at
sales@jct.at



ADVANTAGE / DIS-ADVANTAGE **CONVENTIONAL EXTRACTIVE**

- Relatively simple way of calibrating the entire CEMS
- With individual analyzers: typically no common breakdown possible; Multicomponent Analyzers – reduction on space and accessories
- Requirement of A/C instrument shelter
- With Sample Gas Chillers: probability of loss of components; with High Temperature Systems: probability for higher maintenance and service
- Accuracy of measurement depending on quality of sample handling/ sample transport/sample conditioning
- **SAMPLE HANDLING SYSTEM OFTEN IS NOT PROFESSIONALLY DESIGNED!**



JCT

Analysentechnik
GmbH

www.jct.at
sales@jct.at



ADVANTAGE / DIS-ADVANTAGE

DILUTION EXTRACTIVE

- Relatively simple way of calibrating the entire CEMS
- Dilution reduces interferences from inappropriate sample handling
- With individual analyzers: typically no common breakdown possible
- Requirement of A/C instrument shelter
- Ambient Air Analyzers with lower LDL required = typically more expensive
- Accuracy of measurement depending on stability of dilution; Critical Orifices are sensitive to inlet-pressure changes
- Typically not possible to perform dry-basis-measurement, complex to report dry-basis values



JCT

Analysentechnik
GmbH

www.jct.at
sales@jct.at



QUALITY ASSURANCE 1

USA:

- Quality and Accuracy of CEMS measurements are assured by extensive site acceptance tests after installation and by annual reference calibrations from accredited laboratories

EUROPE:

- Quality Assurance of any CEMS is acc. to EN 14181 and following the QAL-scheme:

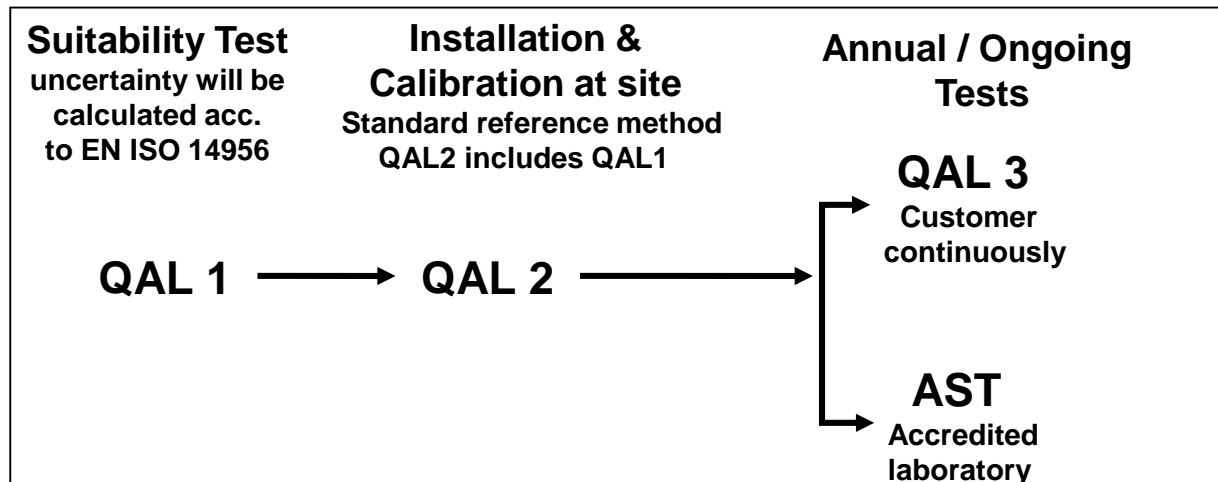

JCT

Analysentechnik
GmbH

www.jct.at
sales@jct.at



QUALITY ASSURANCE 2

EUROPE

QAL 1 is the „TUEV-Test“ (Germany) or MCERTS (UK)
– an *instrument type approval*. In Europe only
instruments having successfully passed QAL 1 are
allowed to be used for statutory monitoring.
Approvals can expire or be revoked. Online
information: www.qal1.de/en



JCT
Analysentechnik
GmbH

www.jct.at
sales@jct.at



QAL 2 is an extensive site acceptance test after installation, performed by an *accredited laboratory or agency*. Testing is for quality of the installation, sample handling, as well as accuracy of the instrumentation. Only QAL 1 approved instrumentation is allowed. QAL 2 to be repeated every five years.

QAL 3 is the ongoing daily quality assurance (zero & span checks, regular maintenance), performed by the *user*.



JCT

Analysentechnik
GmbH

www.jct.at
sales@jct.at





JCT

Analysentechnik
GmbH

www.jct.at
sales@jct.at



AST – Annual Surveillance Test - is a short QAL 2 test to be performed annually by an *accredited laboratory or agency*. If AST fails, the instrumentation has to be rectified and immediately a complete QAL 2 test is required.

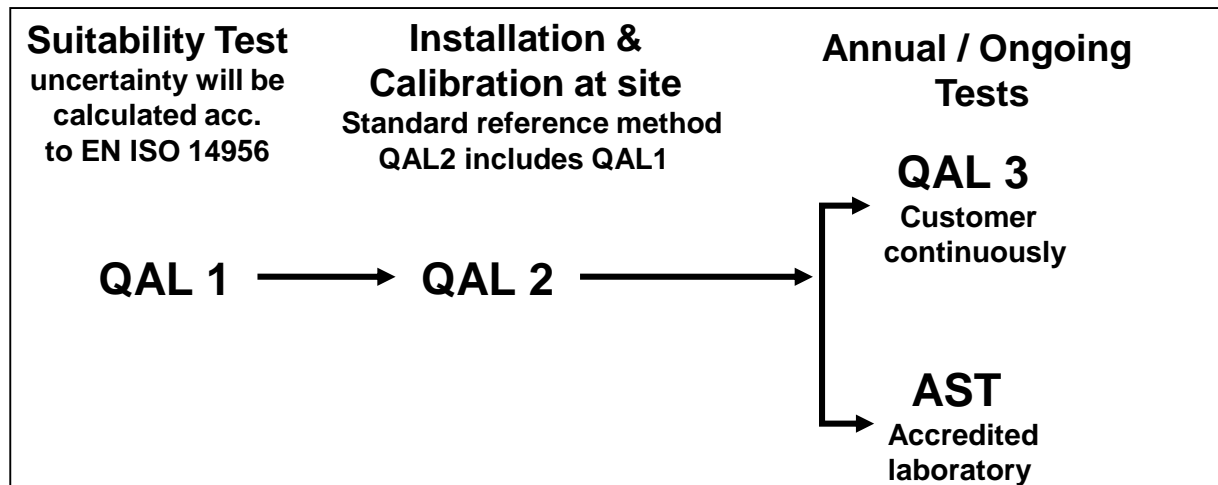

WHY MONITORING AT ALL?

Predictive Emission Monitoring Systems (PEMS) offer an alternative to CEMS:

A PEMS is a software based data acquisition system (Software-CEMS) that is interfaced with the process control system and inputs from the combustion or pollution control process.

It utilizes these inputs to determine the emission rates of the various **gaseous** pollutants that are regulated.

The predictive emissions monitoring system has no gas analyzers, but requires dust / opacity monitors.

An Annual Surveillance Test or RATA is required by using e.g. mobile CEMS.

The main factor defining the possibility for using a PEMS is the fuel used in the process. PEMS requires fuels with very constant conditions. Plants using solid fuels (coal, waste, biomass, etc.) cannot utilize PEMS and require instrumental CEMS.



JCT

Analysentechnik
GmbH

www.jct.at
sales@jct.at



FINAL CONCLUSION

Big Question:

WHAT IS THE RIGHT INSTRUMENT FOR ME???

Simple Answers:

- **All types of QAL-1 approved Analyzers are mature instruments.**
- **Correct Sample Handling & Conditioning for extractive Emission Monitors is essential for an accurate analysis.**
- **In-situ instruments are not always the better way to go!**
- **Not monitoring but Predicting might provide less headaches.**



JCT

Analysentechnik
GmbH

www.jct.at
sales@jct.at



FINAL CONCLUSION 2

The purchasing process takes little time in comparison to the time you or your customer have to life with the instrumentation. Therefore:

- **Select instruments which are Internationally approved.**
- **Support and Service, AMC's and Spare Parts Inventory, Manufacturer's Service Personnel in the country or Manufacturer-trained personnel are essential for a hassle-free operation.**
- **Purchasing requirement must always include at least 2 years of consumables, spare parts, and AMC – this way it is ensured that quality instrumentation is offered.**
- **Try to avoid purchase only based on “L1”, base it on technology!**
- **For larger installations a BOT scheme could be of interest.**



JCT

Analysentechnik
GmbH

www.jct.at
sales@jct.at



THANK YOU

Credits for providing information for this presentation are going to the following companies:



**JCT
Analysentechnik
GmbH**



DURAG GROUP



JCT

Analysentechnik
GmbH

www.jct.at
sales@jct.at



Questions?



sales@jct.at
www.jct.at

Analysing for a better world



JCT

Analysentechnik
GmbH

Questions?
Meet me at booth 13!



sales@jct.at
www.jct.at

Analysing for a better world



JCT

Analysentechnik
GmbH

Thank you for your attention!



sales@jct.at
www.jct.at

Analysing for a better world



JCT

Analysentechnik
GmbH